

(4)

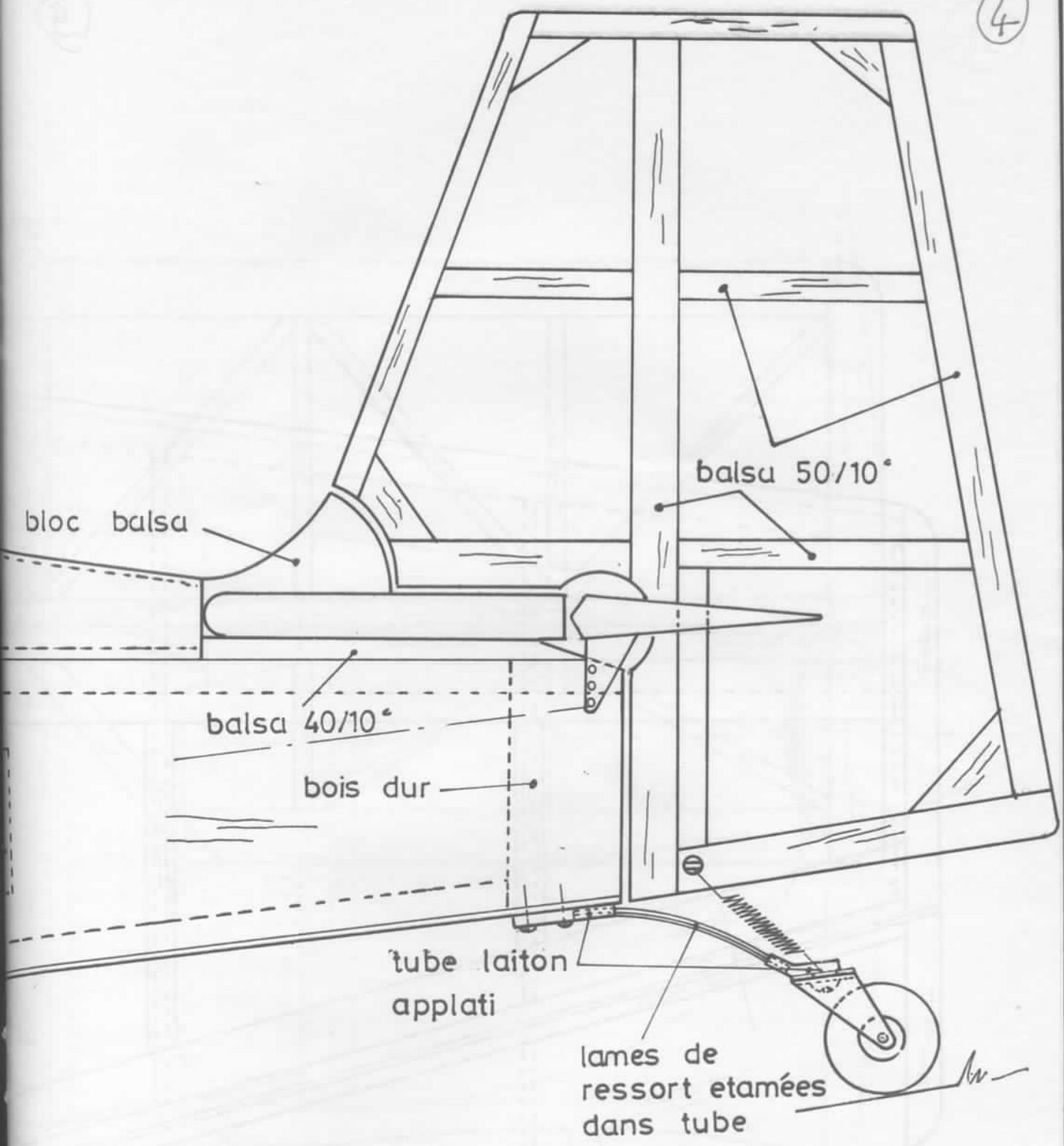

étrier de roulette développée

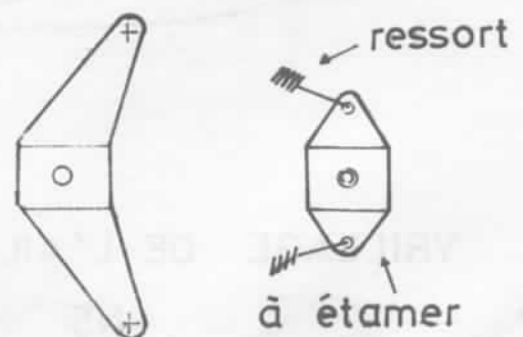

5

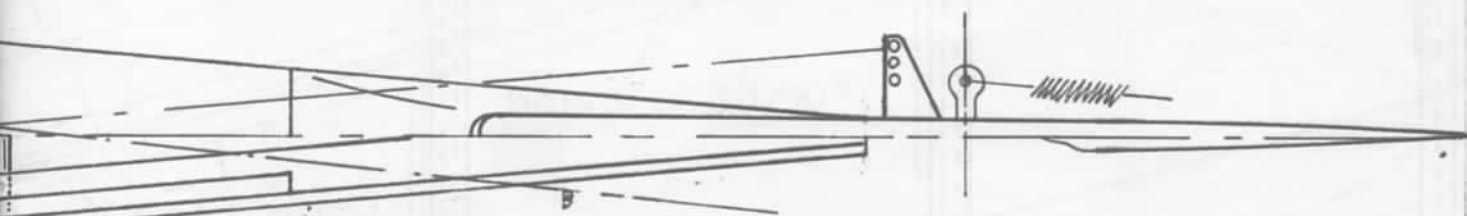
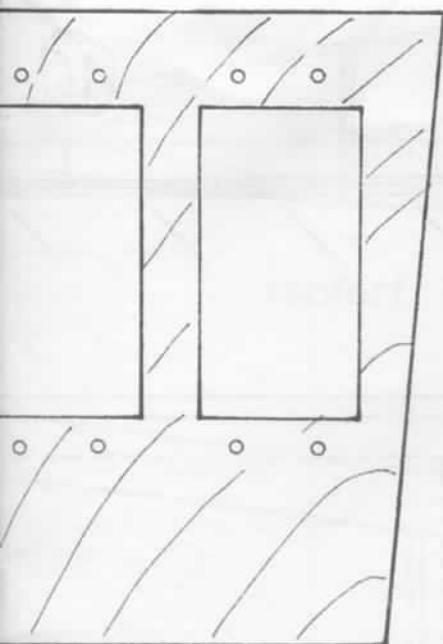

Jodel D9 "Bébé"

Traité en semi-maquette par
Christophe HUSSON CHARLET

Envergure 1.00 m

Moteur 2.5 cc

Plan gratuit MRA n° A 669

C2b
balsa 30/10^e



6

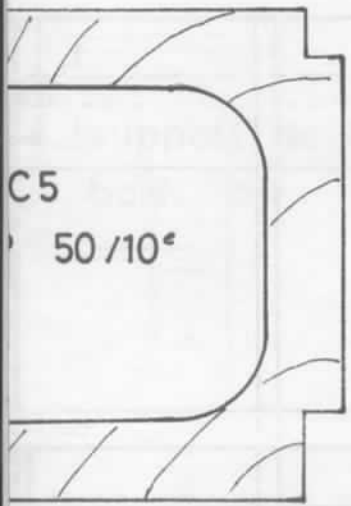

C5
50/10^e



C6
C.T.P 50/10^e

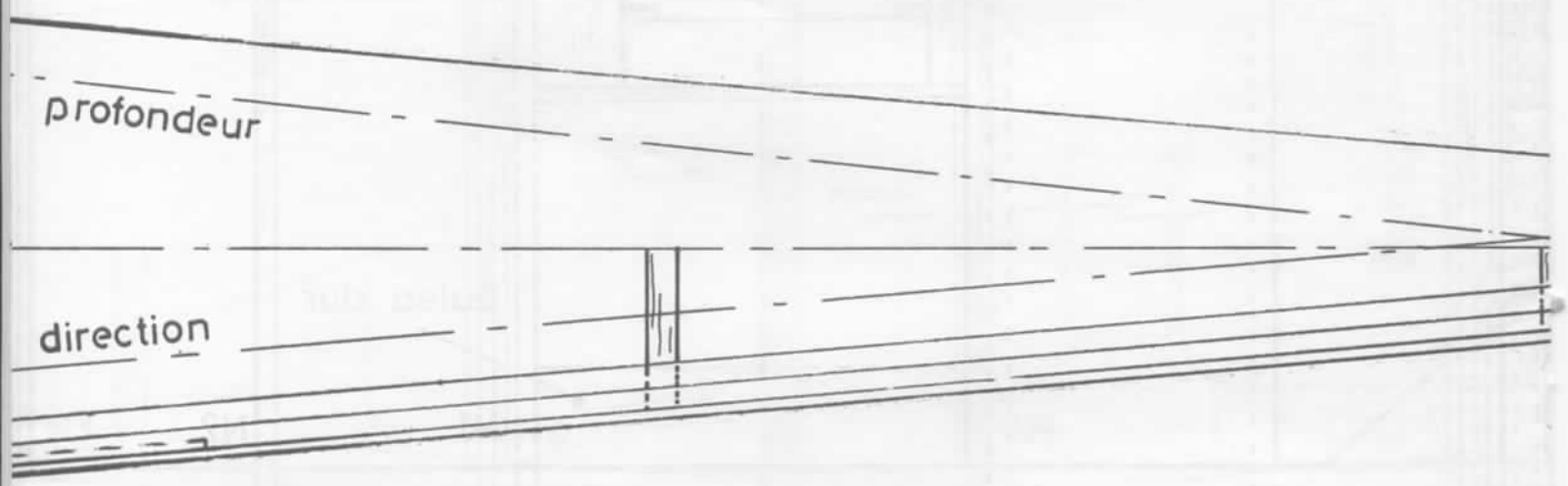

C.T.P 30/10^e

7

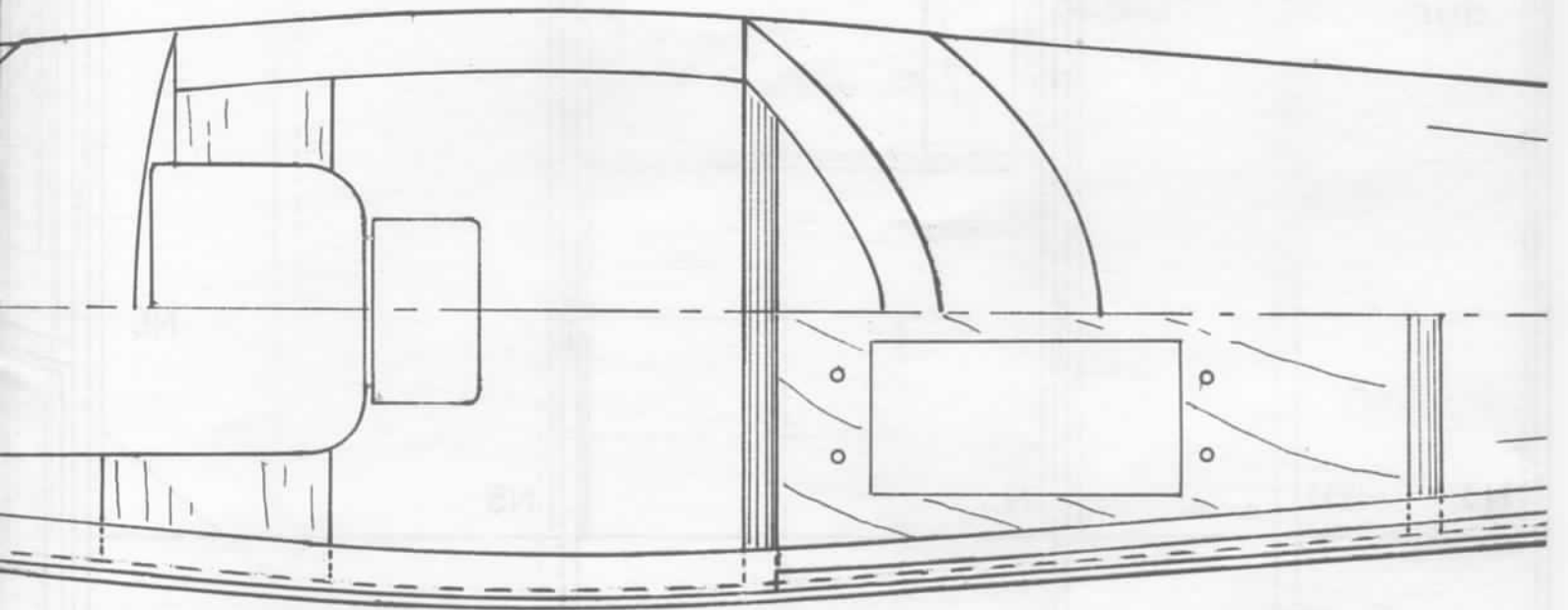
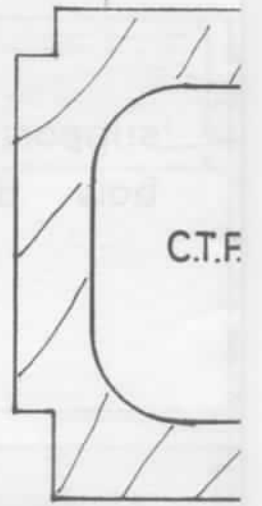
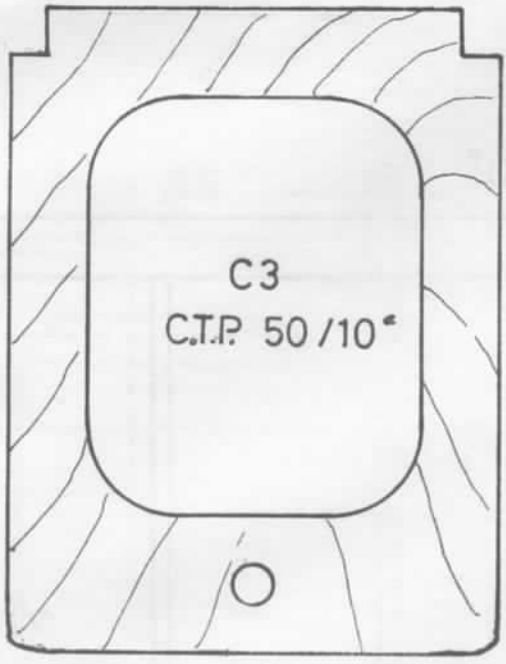

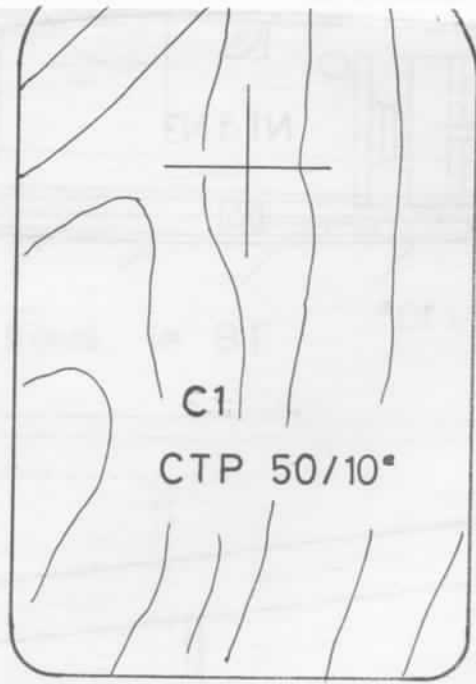

⑧

MLA

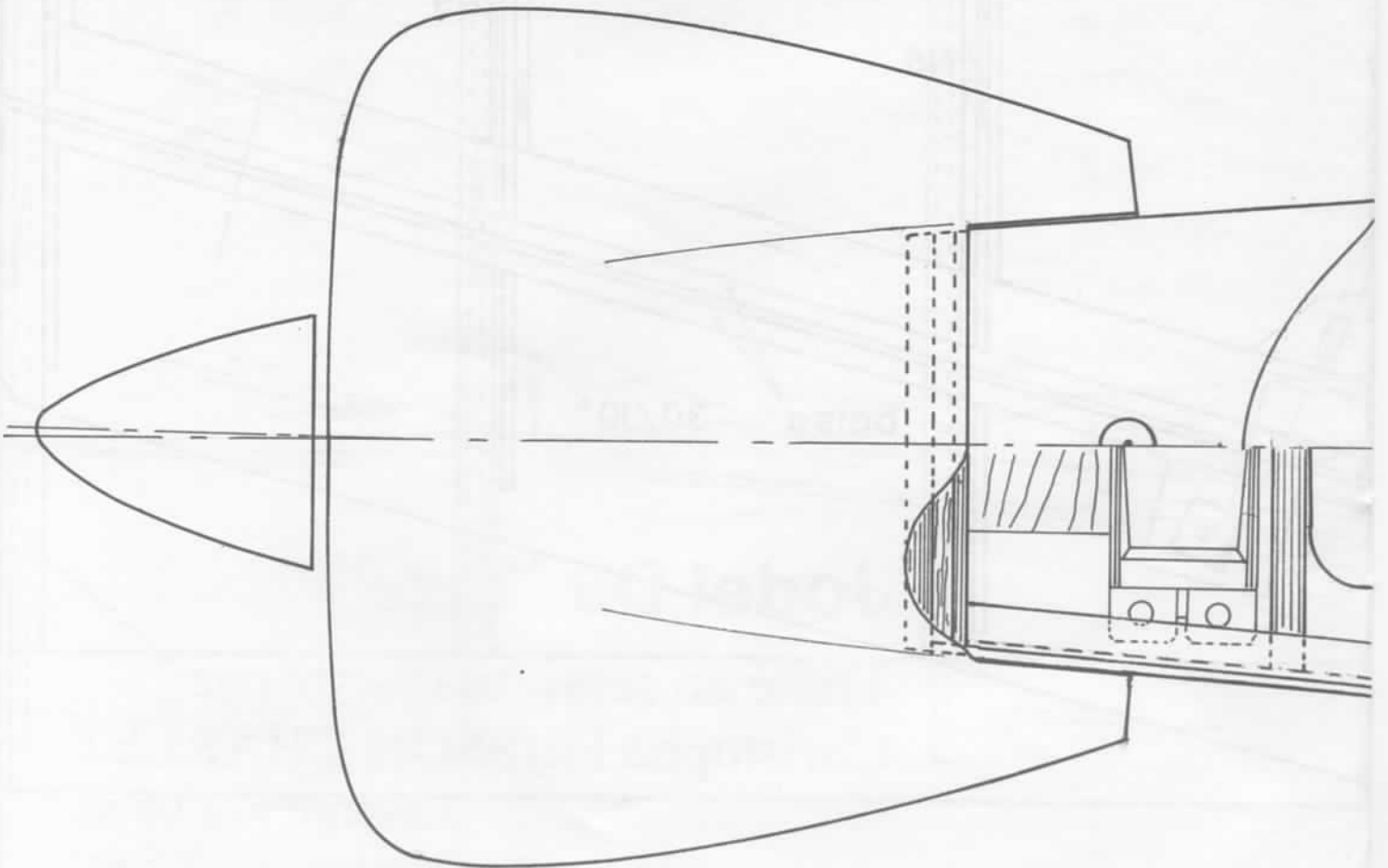
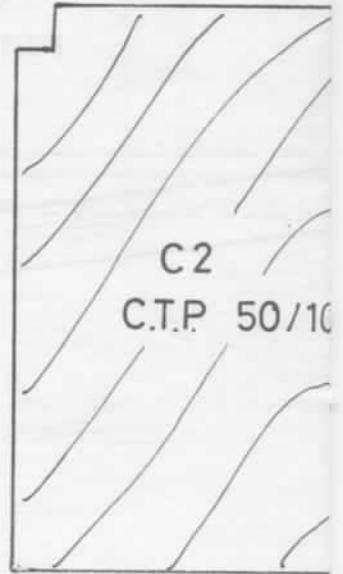

9

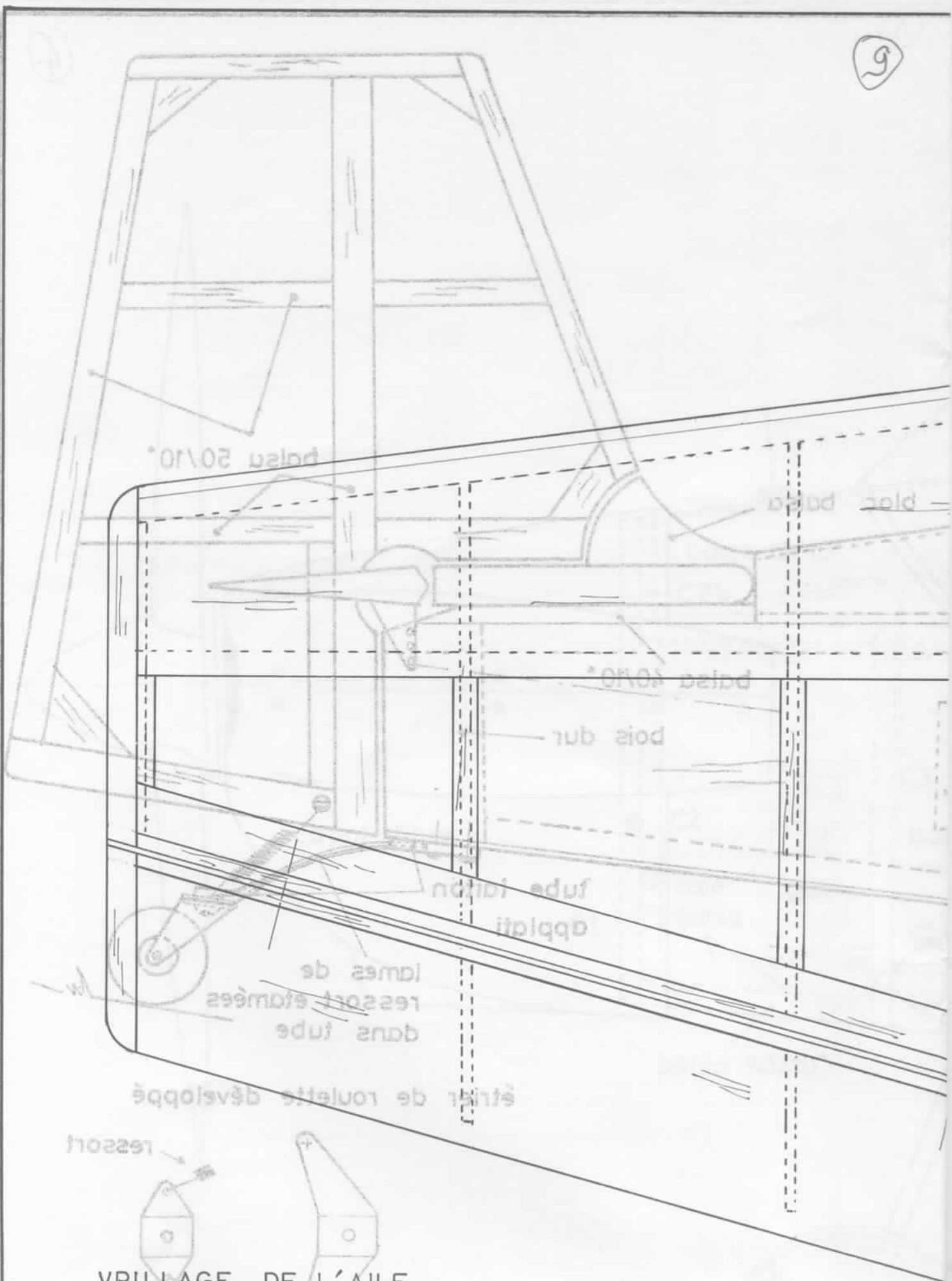

VRILLAGE DE L'AILE

N6

à étamer

N5

N4

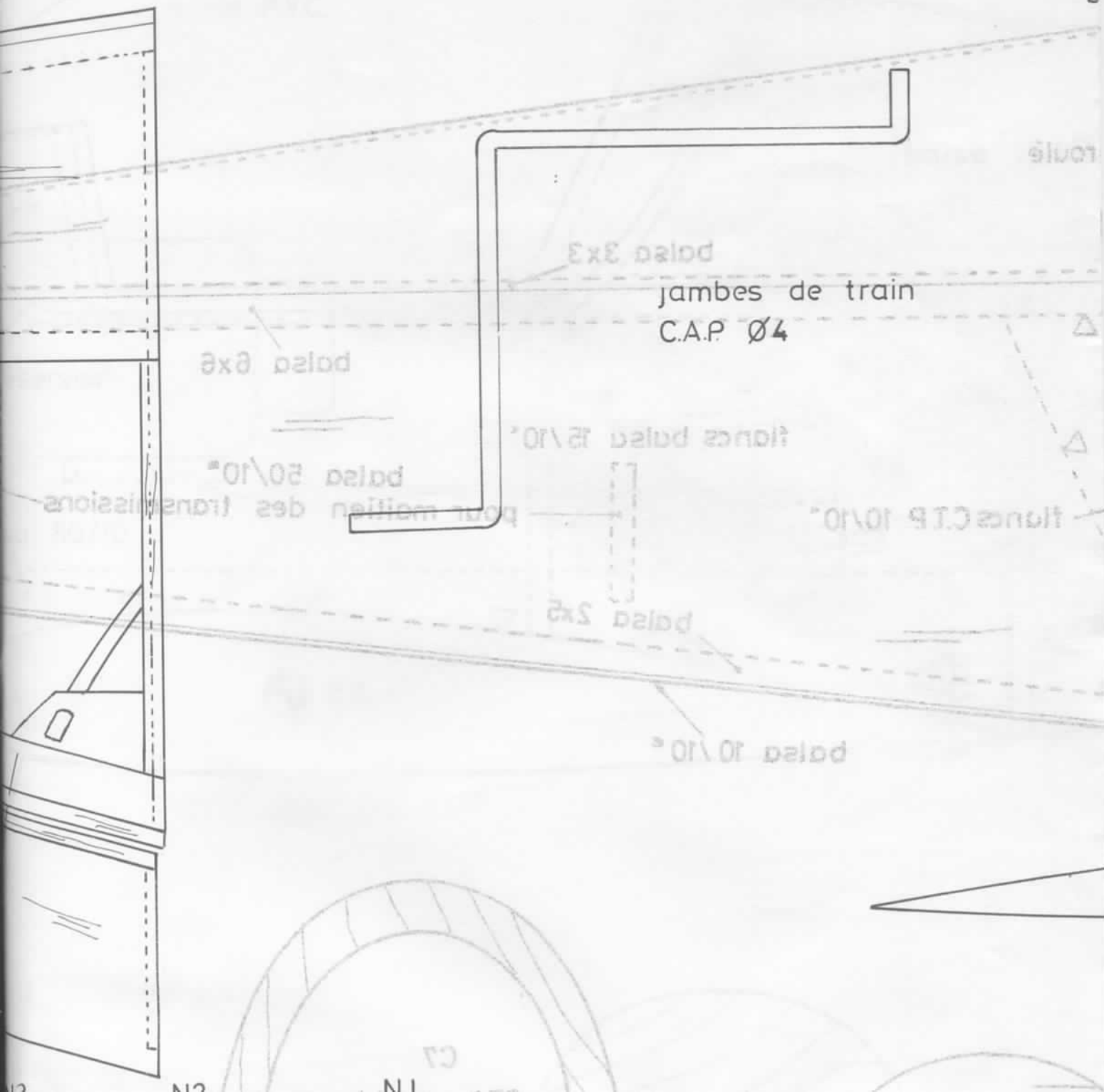

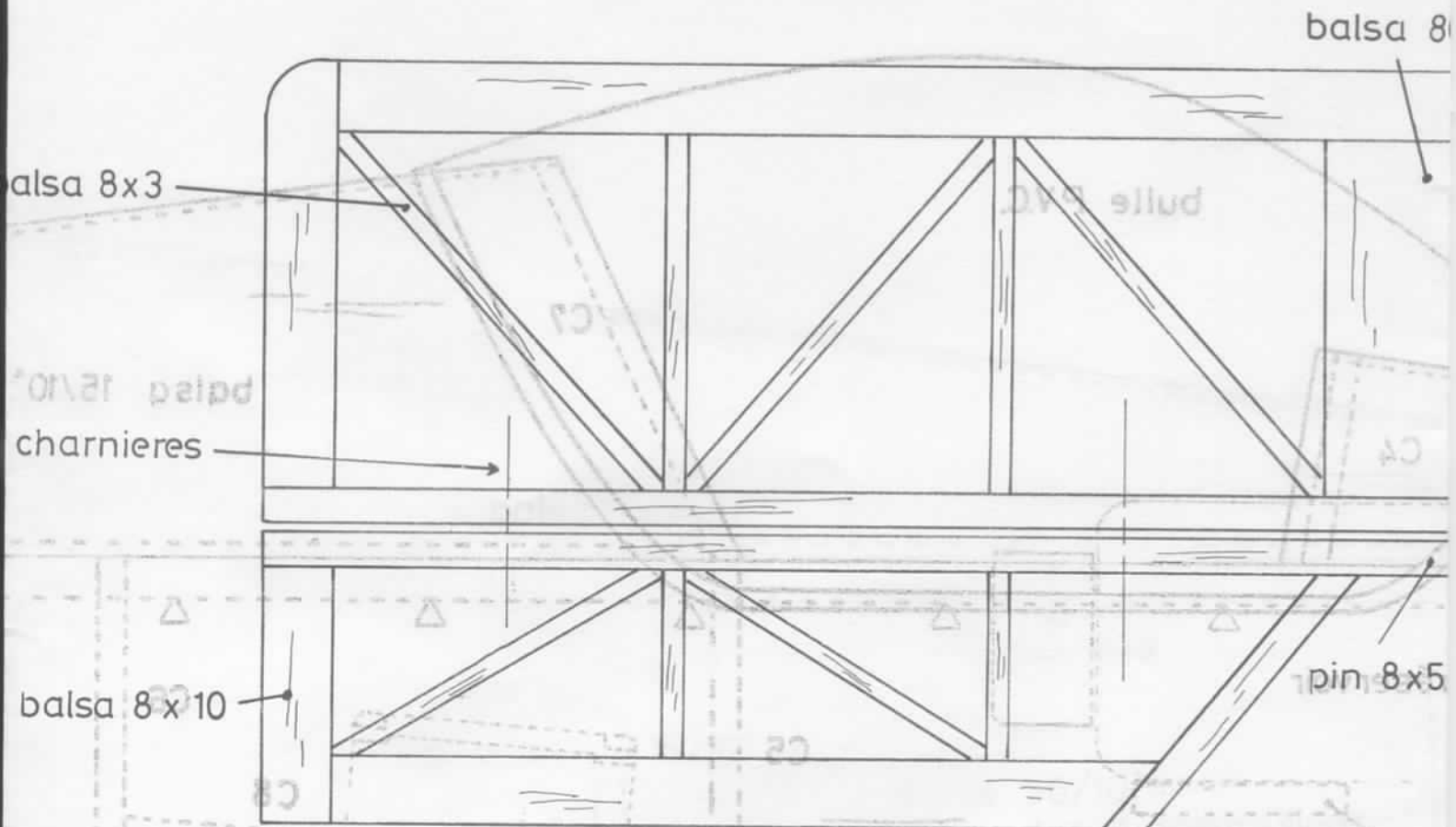

N4 à N10 balsa 15/10°
N1 à N3 C.T.P 20 / 10°

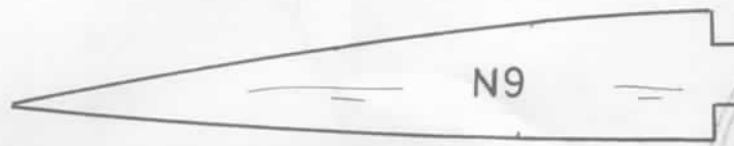
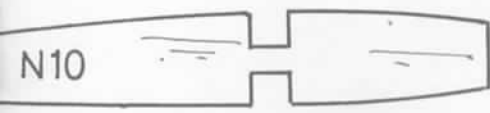

12

0/10

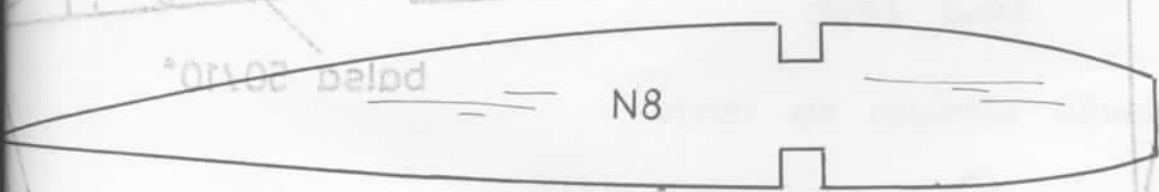
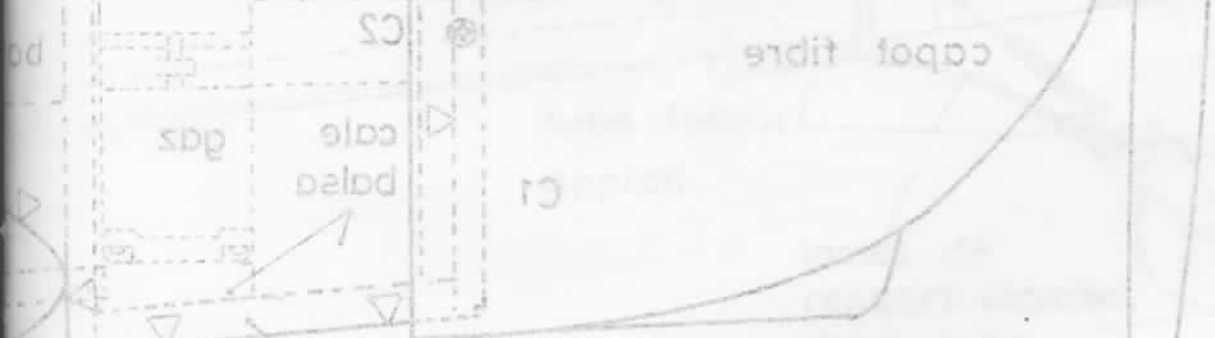
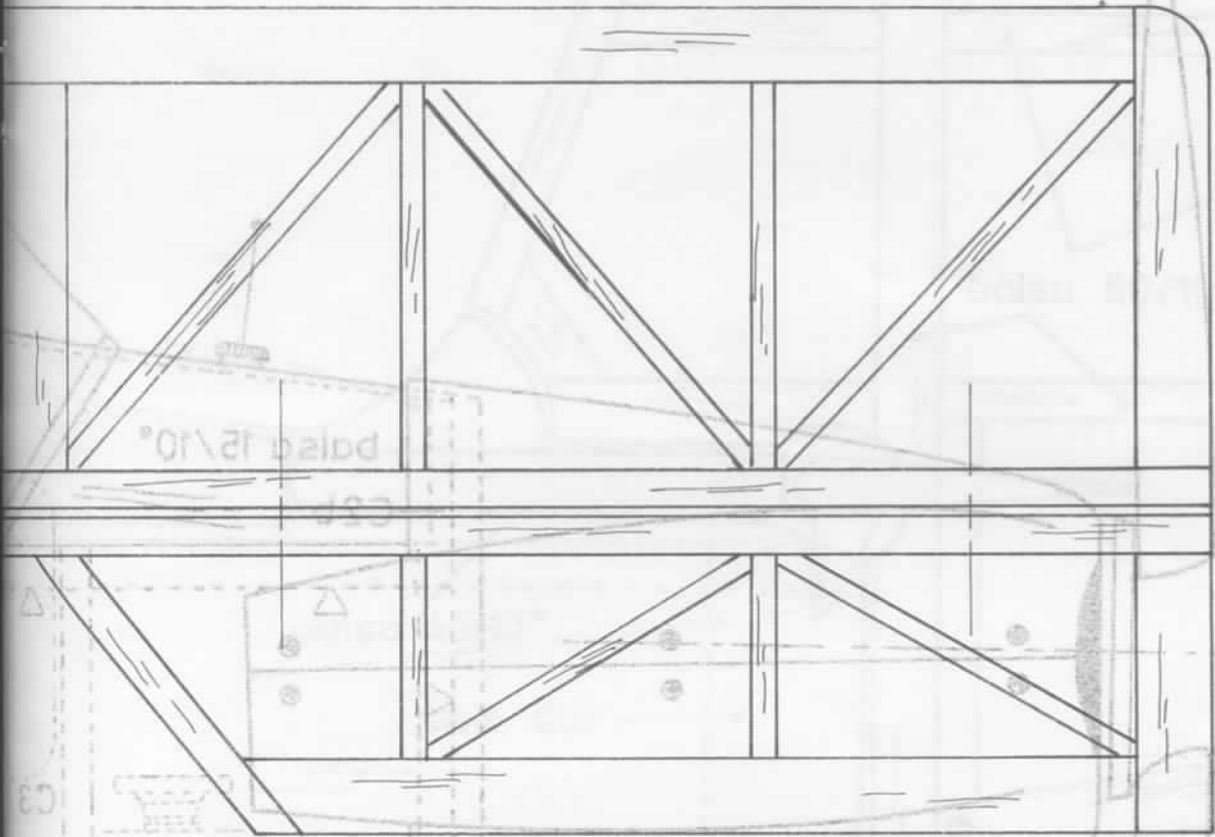

coupe A-A

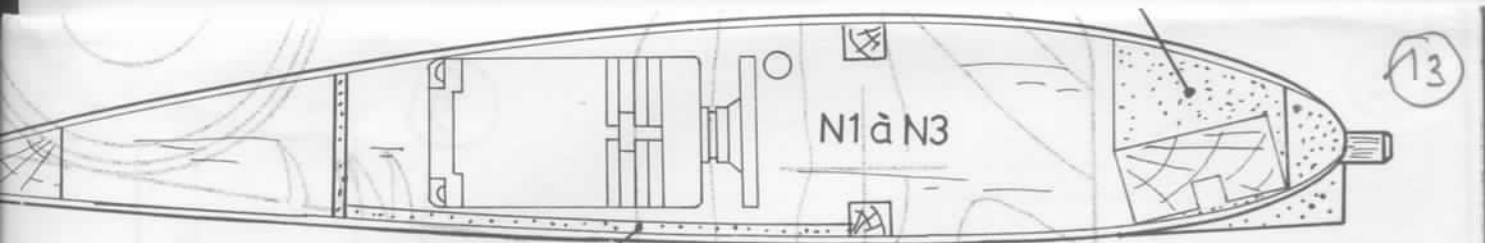

renfort balsa 20/10°

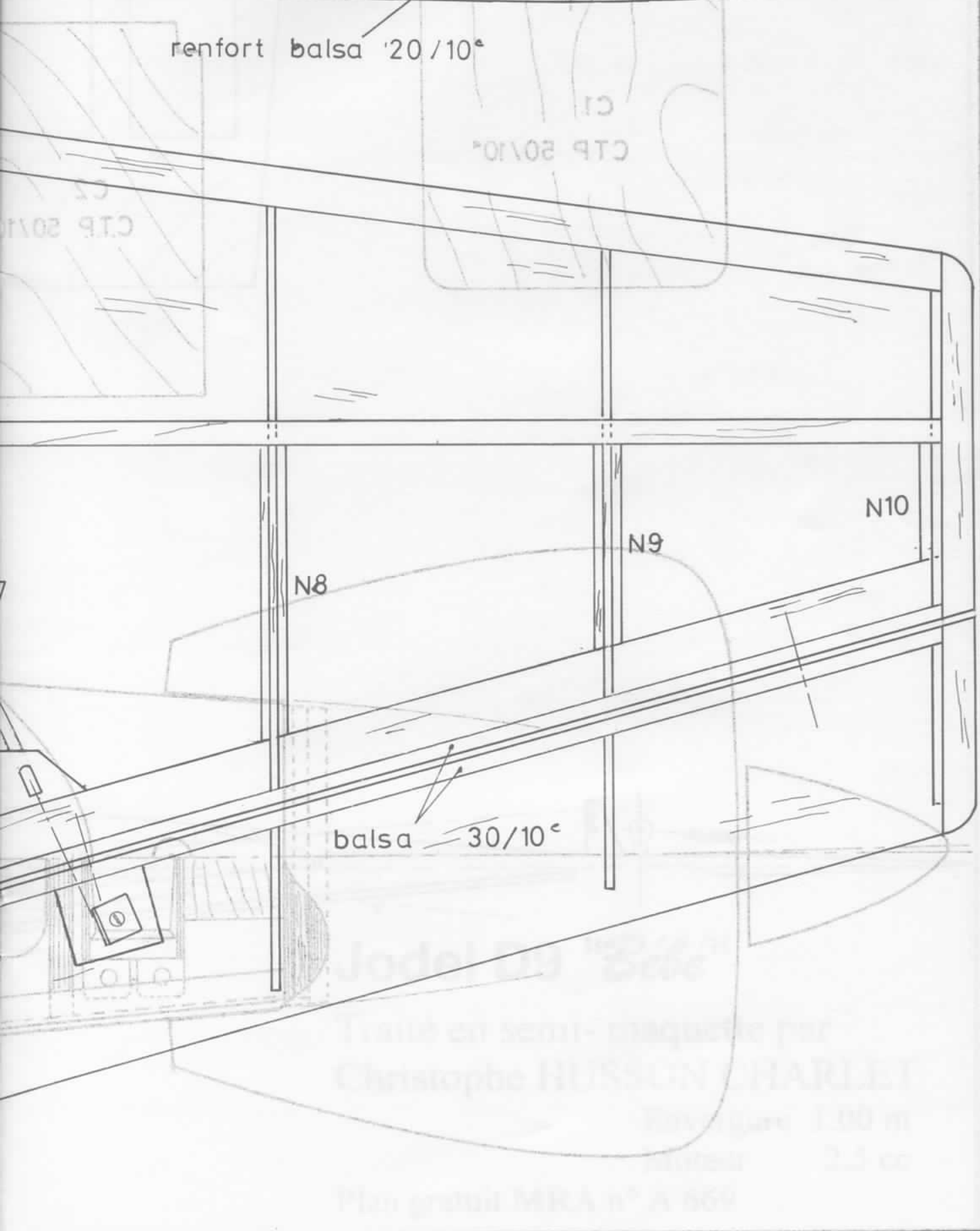

Traité en semi-paqueté par
 Christophe HUSSON CHARLET
 Longueur 1.00 m
 Poids 2.3 kg
 Plan grand MRA n° A 569

cale de diéaire

14

B.A. balsa 80/10^e

support de train
bois dur

pin 5x5

gaine Ø3

recouvrement de
l'aile balsa 10/10^e
dur

N3

N4

N5

N6

N

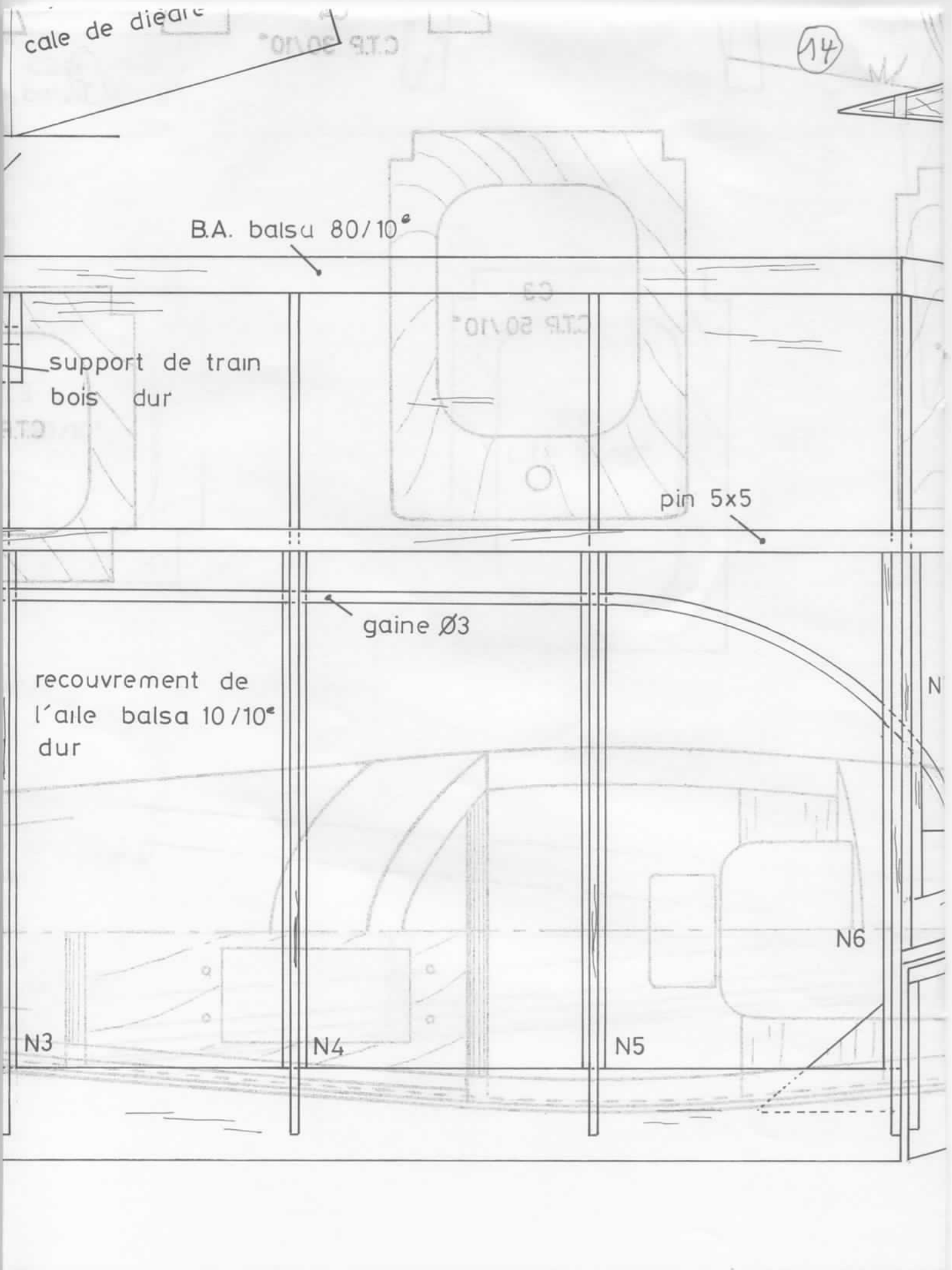

CSP
palea 30/10

(15)

hêtre Ø5

A

cale
balsa

balsa dur

N1

N2

A

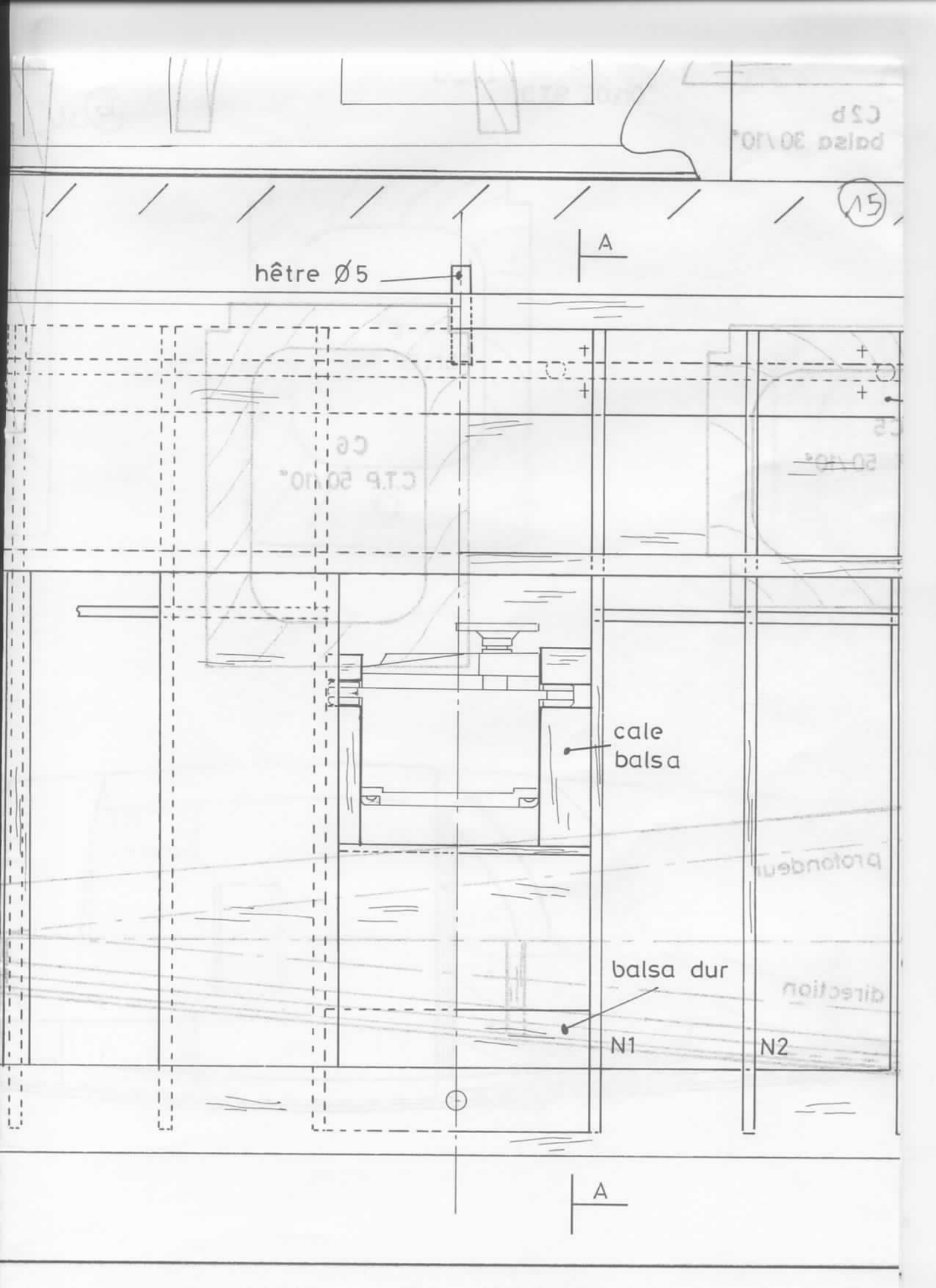

16

cale de 3mm sous le B.F.



Jobel Da "3ème"

Traité en semi-madrette par
Christophe HUSSON CHARLET

Envergure 1.00 m
Moteur 2.2 cc

Plan gratuit MRA n° A 669